



### DVA/DVAH Vibration Absorber 50 and 120 bar Models

**Product Features:**

- 120 bar Version completely made of stainless steel
- 50 bar Version with Copper and stainless steel connection (depends on connection size)
- Can be installed without cooling
- Connections are TIG welded

**Technical data**

<b>CE marking acc. PED</b>	Art. 4.3 Cat. I with CE	<b>Media compatibility</b>	CO <sub>2</sub> , Mineral-, Synthetic-, POE- und PAG Oil
<b>Applicable Standards</b>	EN 378-2, EN1476-1	<b>Material</b>	Housing: St. Steel (EN 10088-1) Bellows: St. Steel (EN 10028-7) Connections see table below
<b>Pressure Rating</b>	PS: see table below PTest: = PS x 1,1	<b>Temperature Range</b>	-10°C ... 120°C (optional 108°C)

Model	P/N	Operating Pressure (bar)	Dimension				Connection Material	PED / Module Fluid II	PED / Module Fluid I
			A (mm)	B (mm)	S (mm)	D1 (mm).			
DVA-12*	17455	50	230	20	1,5	12	Copper	Art. 4.3	
DVA-16*	17456		255	25		16			
DVA-22*	17457		290			22			
DVA-28	17458		330			28			
DVA-35	17459		45	375		30			35
DVA-42	17460	430		42					
DVA-54	17461	510		54					
DVA-64	17462	25	690	80	64				
DVAH-12*	17450	120	230	30	2,5	12	St. Steel	Art. 4.3	
DVAH-16*	17451		255			16			
DVAH-18*	17452		255			18			
DVAH-22*	17453		290			22			
DVAH-28	17454		330			28			

\*These Models can be used also with Fluid I Refrigerants

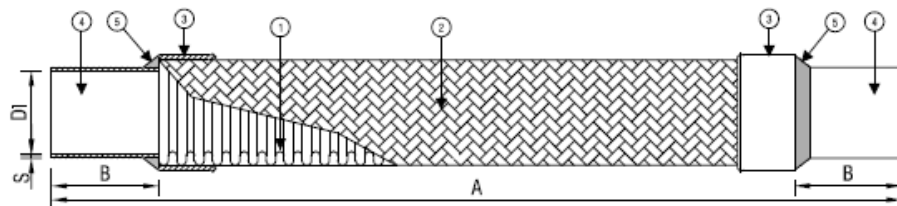

- 1: Bellows
- 2: Steel braiding
- 3: Conn. Ring
- 4: Braze-/Welding conn.
- 5: TIG Welding

**Tabelle 1**

Refrigerant	Group acc. PED 2014/68/EC	Group acc. EN378	Refrigerant	Group acc. PED 2014/68/EC	Group acc. EN378
R404A R134a R448A R449A R450A R513A R744	II	A1	R1234ze (E) R1234yf R32 R455A R454C	I	A2L
			R1270 R290		

Typical transcritical CO<sub>2</sub> Cycle

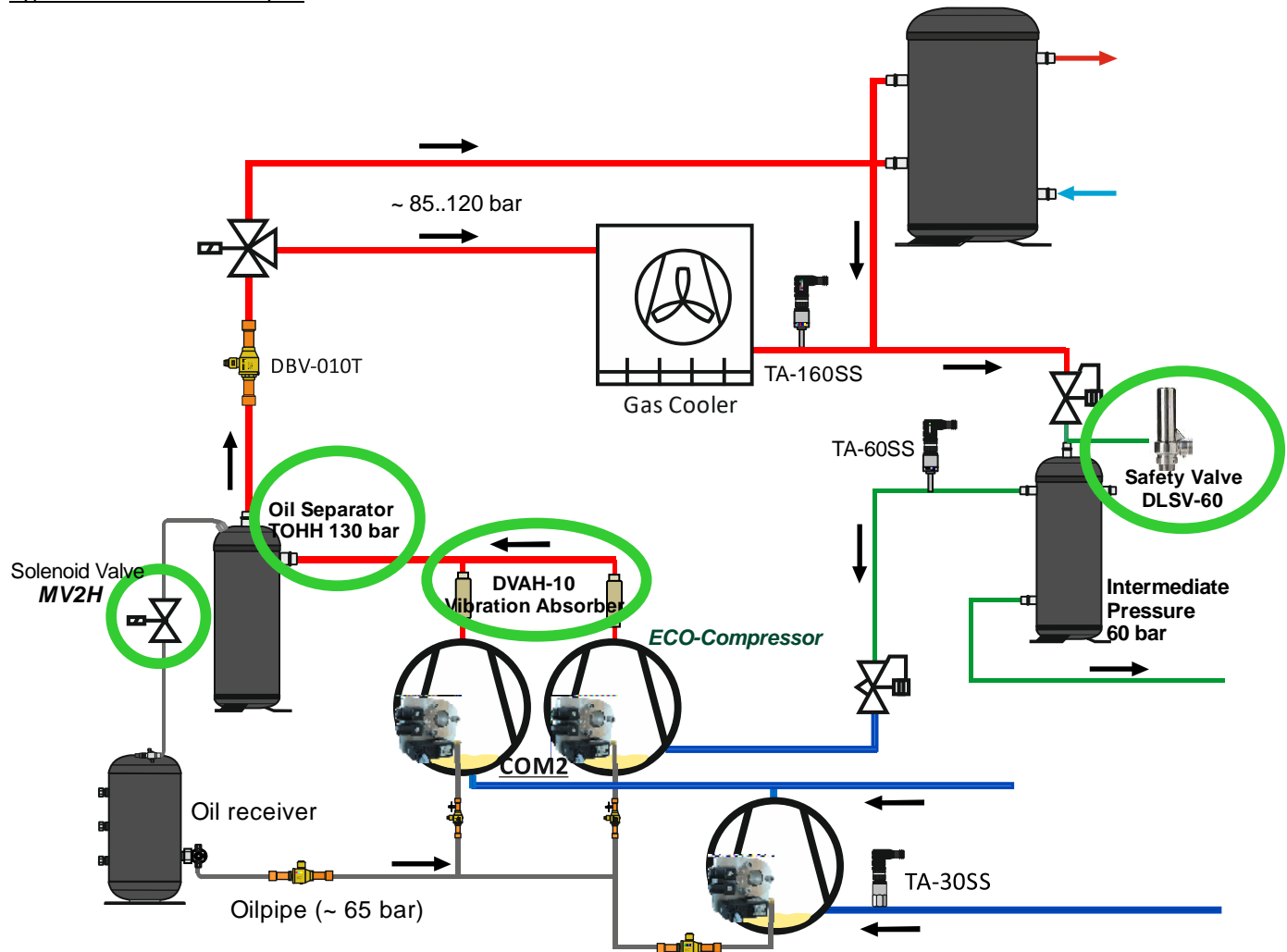

DEKA Controls will not accept responsibility for possible errors in Technical literature and other printed material. DEKA Controls reserves the right to change his products without notice. This applies also to products already on order provided that such changes can be made without sub sequential changes being necessary in specifications already agreed.